

Gunnison County, Colorado
WOODSTOVE/GAS APPLIANCE IDENTIFICATION

Gunnison County Planning Department
 221 N. Wisconsin St. Suite D, Gunnison, CO 81230 (970) 641-0360
 Website: www.gunnisoncounty.org

Parcel No. of Property (available from Gunnison County Assessor's records):
Legal Description of Property:
Street Address of Property:
Name of Owner of Property:

Type of Building(s) in which the device(s) will be located:

<input type="checkbox"/> Single-family Residence	<input type="checkbox"/> Sleeping Quarters
<input type="checkbox"/> Duplex	<input type="checkbox"/> Garage/Workshop
<input type="checkbox"/> Multiple-family Residence	<input type="checkbox"/> Commercial
	<input type="checkbox"/> Other

List ALL devices that are/will be on the parcel of property (include devices in garages, shops, accessory buildings, etc.)

Type of Device	Room in which device is located	Existing Device	New Device	Make & Model No. of Device
EPA Certified Solid Fuel-Burning Device				
Rumford-style Fireplace (EPA Certified)				
Gas Log Fireplace (Meets all codes for burning wood, but is used w/ gas logs. Not allowed in sleeping rooms.)				
Gas Fireplace Appliance				
Other (masonry heater, pellet stove)				

If any devices are being removed, please describe (i.e. "old woodstove removed from living room").

Signature of Applicant _____ Date _____

WOODSTOVE/ FIREPLACE INSPECTION FORM
GUNNISON COUNTY PLANNING DEPARTMENT
 BUILDING OFFICE
 221 N. WISCONSIN ST. SUITE D
 GUNNISON, CO 81230

Job Address	OWNER INFO.	Name
Locality		Address
Legal Description		City Phone

STOVE INFORMATION

DATE INSTALLED	INSTALLED BY	PURCHASE COST \$
MAKE/MODEL	Listed appliance <input type="checkbox"/> Yes <input type="checkbox"/> No	USE <input type="checkbox"/> PRIMARY HEAT <input type="checkbox"/> AUXILIARY HEAT <input type="checkbox"/> COOKING <input type="checkbox"/> OTHER (specify):
TYPE <input type="checkbox"/> RADIANT <input type="checkbox"/> JACKETED <input type="checkbox"/> CIRCULATING	WHAT TYPE OF FUEL IS USED?	
HOW OFTEN ARE CHIMNEY AND STOVE PIPES CLEANED?	DATE LAST CLEANED	BY WHOM

INSTALLATION INFORMATION

LOCATION OF STOVE IN HOME	IS A SMOKE DETECTOR IN THIS ROOM? <input type="checkbox"/> YES <input type="checkbox"/> NO
FLOOR PROTECTION <input type="checkbox"/> ASBESTOS MILLBOARD COVERED WITH METAL <input type="checkbox"/> METAL <input type="checkbox"/> STONE/BRICK <input type="checkbox"/> OTHER (Describe):	
WALL PROTECTION <input type="checkbox"/> ASBESTOS MILLBOARD COVERED WITH METAL <input type="checkbox"/> METAL <input type="checkbox"/> ASBESTOS MILLBOARD <input type="checkbox"/> OTHER (Describe):	IF NONE IS THIS ACCEPTABLE WITH THE MANUFACTURER? <input type="checkbox"/> YES <input type="checkbox"/> NO
CHIMNEY TYPE <input type="checkbox"/> FACTORY CHIMNEY <input type="checkbox"/> MASONRY <input type="checkbox"/> OTHER (Describe):	IF FACTORY CHIMNEY IS IT U.L./ALL FUELS LISTED? <input type="checkbox"/> YES <input type="checkbox"/> NO
DOES VENT PASS THROUGH A COMBUSTIBLE PARTITION? <input type="checkbox"/> YES <input type="checkbox"/> NO	IF YES, IS PROTECTION THIMBLE OR SLEEVED USED? <input type="checkbox"/> YES <input type="checkbox"/> NO
	DOES PIPE VENT PASS DIRECTLY THROUGH THE ROOF? <input type="checkbox"/> YES <input type="checkbox"/> NO
	TYPE OF FIRE PROTECTION USED AT CEILING:

CLEARANCES

1.	_____ INCHES	SIDE OF UNIT NEAREST TO WALL
2.	_____ INCHES	REAR OF UNIT TO WALL
3.	_____ INCHES	TOP OF STOVE PIPE TO CEILING
4.	_____ INCHES	BOTTOM OF UNIT TO FLOOR
5.	_____ INCHES	FRONT OF UNIT TO FRONT EDGE OF FLOOR PROTECTION
6.	_____ INCHES	SIZE OF PIPE USED
7.	_____ INCHES	SIZE OF THIMBLE OR ROOF JOIST SHIELD
8.	DO THESE DISTANCES COMPLY WITH THE MANUFACTURERS STANDARDS? <input type="checkbox"/> YES <input type="checkbox"/> NO	

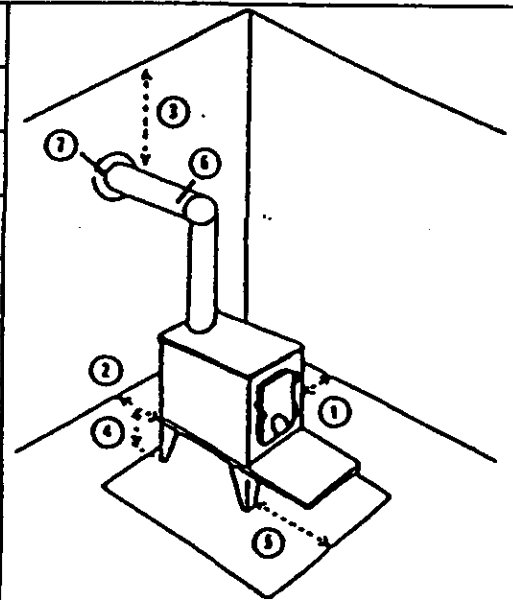

REMARKS:

INSPECTOR

SIGNATURE	TITLE
DATE	TELEPHONE NUMBER

GUNNISON COUNTY LAND USE RESOLUTION

Amended February 18, 2003; Resolution No. 22, Series 2003

Amended October 23, 2003; Resolution No. 54, Series 2003

Amended August 1, 2006; Resolution No. 06-56

SECTION 2-102: DEFINITIONS.

SOLID FUEL BURNING DEVICES means the following:

•**APPROVED NON-SOLID FUEL BURNING DEVICE** means a device that burns a non-solid fuel including natural gas, liquefied petroleum (LP), fuel oil, or similar fuel that has been approved by Underwriter's Laboratory, International Approval Services (IAS) or other approved laboratories. This includes gas logs permanently installed in a traditional open fireplace.

•**APPROVED SOLID FUEL BURNING DEVICE** means a device that is designed or intended to burn solid fuel and that is certified to meet the E.P.A. Phase II particulate emissions rate standard by the U.S. Environmental Protection Agency, or is certified to meet those standards by a testing laboratory accredited by the E.P.A., or is approved by the Colorado Air Quality Control Commission.

•**SOLID FUEL BURNING DEVICE** means a device designed for the combustion of solid fuels including, but not limited to, wood, coal, pulp, paper, pellets or similar non-liquid or non-gaseous materials so that usable heat is derived for the interior of a building, and includes solid fuel burning stoves, fireplaces or wood stoves of any nature, combination fuel furnaces or heaters that burn solid fuel, or any other device used for the burning of solid combustible material.

SECTION 13-107: INSTALLATION OF SOLID-FUEL-BURNING DEVICES

A. PURPOSE. The purpose of this Section is to minimize air pollution caused by solid-fuel-burning devices emissions by regulating their use, and to encourage the use of other heating alternatives that achieve better emission performance and heating efficiency and that comply with the emissions performance standards as adopted by the Colorado Department of Public Health and Environment Air Quality Control Commission. It is further the policy of the Board to encourage the replacement of non-approved devices with cleaner sources of heat.

B. APPLICABILITY.

1. **NEW STRUCTURES REQUIRING BUILDING PERMITS.** Any structure for which a Building Permit is requested or required after the effective date of this *Resolution* shall be required to comply with this Section. When a new portion of a structure requires a Building Permit, and a solid-fuel-burning device is to be located in that new portion, that solid-fuel-burning device shall comply with this Section.
2. **NEW STRUCTURES THAT DO NOT REQUIRE BUILDING PERMITS.** Any new structure for which no Building Permit is required, as defined by this *Resolution*, by the applicable building code, adopted and amended by Gunnison County, or by any other code or regulation adopted by Gunnison County, shall be required to comply with this Section.
3. **EXISTING DEVICES IN EXISTING STRUCTURES.** Any solid fuel-burning device, including coal-fired furnaces, existing in an existing structure as of the effective date

of this *Resolution* is not required to be replaced, except that any non-approved solid-fuel-burning device, when replaced or relocated, shall comply with Section 13-107: J: *Replacement or Modification of Solid Fuel- Burning Devices*.

4. **DEVICES DESIGNED FOR HEATING A STRUCTURE, LOCATED OUTSIDE OF A STRUCTURE.** Any solid fuel-burning device designed for heating a structure, including but not limited to, solid fuel-burning furnaces or boilers located outside of the structure, shall be required to be an approved solid fuel-burning device.

C. LIMITATION ON NUMBER OF DEVICES.

1. **SINGLE FAMILY RESIDENCES.** Any single-family residential structure, manufactured home, or mobile home located outside of a mobile home community, for which a Building, Manufactured Home or Mobile Home Permit is issued after the effective date of this *Resolution*, shall be allowed to install two approved solid-fuel-burning devices per single family residence. A mobile home located within a mobile home community shall be limited to the installation of one approved solid fuel-burning device per mobile home.
2. **MULTIPLE-FAMILY RESIDENCES, HOTELS, COMMERCIAL AND INDUSTRIAL BUILDINGS.** No solid-fuel-burning device shall be allowed in individual units of multiple-family buildings, hotel/motel units, commercial or industrial buildings, except that two approved solid-fuel-burning devices may be installed per building.

- D. LIMITATION ON NUMBER OF DEVICES IN AREAS AROUND THE TOWNS OF CRESTED BUTTE AND MT. CRESTED BUTTE.** When the land is located within the boundaries of a municipal three mile plan area defined within a Three-Mile Plan of the Towns of Crested Butte and Mt. Crested Butte, the installation of solid-fuel devices shall comply with the following standards, or if an adopted intergovernmental agreement between either town and the County identifies specific standards regarding the installation of solid fuel-burning devices, the standards identified within the intergovernmental agreement shall prevail:

1. **SINGLE FAMILY RESIDENCES.** Any single-family residential structure, manufactured or mobile home for which a Building, Manufactured Home or Mobile Home Permit is issued after the effective date of this *Resolution* shall be allowed to install one approved solid-fuel-burning device per single family residence.
2. **MULTIPLE-FAMILY RESIDENCES, HOTELS, COMMERCIAL AND INDUSTRIAL BUILDINGS.** No solid-fuel-burning device shall be allowed in individual units of multiple-family buildings, hotel/motel units, commercial or industrial buildings, except that one approved solid-fuel-burning device may be installed per building.

- E. LIMITATION ON NUMBER OF DEVICES IN AREAS AROUND THE CITY OF GUNNISON.** When the land is located within the boundaries of the municipal three mile plan area defined within the Three-Mile Plan of the City of Gunnison, the installation of solid-fuel devices shall comply with the following standards, or if an adopted intergovernmental agreement between the city and the County identifies specific standards regarding the installation of solid fuel-burning devices, the standards identified within the intergovernmental agreement shall prevail:

1. **SINGLE FAMILY RESIDENCES.** Any single-family residential structure, manufactured home, or mobile home outside of a mobile home community, for which a Building, Manufactured Home or Mobile Home Permit is issued after the effective date of this *Resolution*, shall be allowed to install two approved solid-fuel-burning

devices per single family residence. A mobile home located within a mobile home community shall be limited to the installation of one approved solid fuel-burning device per mobile home.

2, MULTIPLE-FAMILY RESIDENCES, HOTELS, COMMERCIAL AND INDUSTRIAL BUILDINGS. No solid-fuel-burning device shall be allowed in individual units of multiple-family buildings, hotel/motel units, commercial or industrial buildings, except that two approved solid-fuel-burning devices may be installed per building.

- F. COMPLIANCE IN SPECIAL GEOGRAPHIC AREAS.** When the County has adopted requirements governing development review, permitting or inspections of solid fuel-burning devices in designated special geographic areas, the more restrictive requirements shall apply to solid fuel-burning devices in that particular area.
- G. NO ADDITIONAL DEVICES.** In existing structures that have two or more solid-fuel-burning devices as of the effective date of this *Resolution*, an additional one shall not be installed.
- H. ACCESSORY STRUCTURES.** One approved solid-fuel-burning device is allowed per non-residential structure that is accessory to a residence, for temporary or sporadic use, whether the structure is attached or detached.
- I. NO LIMIT TO NUMBER OF NON-SOLID-FUEL-BURNING DEVICES.** There is no limitation on the number of approved non-solid-fuel-burning devices that may be installed in any structure, so long as they all comply with all applicable federal, state and County codes and regulations.
- J. REPLACEMENT OR MODIFICATION OF SOLID FUEL-BURNING DEVICES.** Any non-approved solid fuel-burning device that requires replacement or relocation shall be required to be removed and replaced with an approved solid fuel-burning device, or approved non-solid fuel burning device. Replacement of a non-approved device in one condominium or townhouse unit shall not affect devices in other units.
- K. INSTALLATION.** Devices shall be installed as follows:
- 1. SOLID-FUEL-BURNING DEVICE.** Any solid-fuel-burning device shall be installed pursuant to the standards and specifications defined by the manufacturer of that device, or shall meet the clearances specified in the *International Mechanical Code*.
 - 2. NON-SOLID-FUEL-BURNING DEVICE.** Any non-solid-fuel-burning device shall be installed pursuant to the standards and specifications of its manufacturer and the *International Fuel-Gas Code*.
- L. INSPECTION.** The installation of any solid-fuel-burning device or non-solid-fuel-burning device shall be subject to inspection and approval by the Gunnison County Building Inspector and, as applicable, by the applicable fire protection district in which the device is located. Only the affected unit will be inspected.
- M. FEES.** Inspection fees shall be as delineated in a schedule of fees charged for permits issued by the Planning Department, adopted and amended from time to time by the Board of Commissioners.
- N. SPARK ARRESTORS.** Spark arrestors shall be required in all solid-fuel-burning device systems to which this Section applies pursuant to Section 13-107: B.1.: *New Structures Requiring Building Permits*, Section 13-107: B. 2.: *New Structures That Do Not Require Building Permits*, and Section 13-107: B. 3.: *Existing Devices in Existing Structures*.

**ACKNOWLEDGMENT OF
SECTION 13-107: INSTALLATION OF SOLID FUEL-BURNING DEVICES
GUNNISON COUNTY LAND USE RESOLUTION**

Section 13-107 Installation of Solid Fuel-Burning Devices in the *Gunnison County Land Use Resolution* requires all new structures to comply with this Section. All proposed solid fuel-burning devices shall be an approved solid fuel-burning devices, as certified by the U.S. Environmental Protection Agency, or is certified to meet those standards by a testing laboratory accredited by the E.P.A. The E.P.A. continually updates its list of certified woodstoves; a list of the most current approved solid fuel-burning devices can be found at www.epa.gov/oecaerth/resources/publications/monitoring/caa/woodstoves/certifiedwood.pdf.

Any single family residential structure located within the municipal three mile plan area of the Towns of Crested Butte or Mt. Crested Butte shall have no more than one approved solid fuel-burning devices per single family residence.

Any single family residential structure located within the municipal three mile plan area of the City of Gunnison shall have no more than two approved solid fuel-burning devices per single family residence.

Any single family residential structure located outside of a municipal three mile plan area shall have no more than two approved solid fuel-burning devices per single family residence.

Any solid fuel-burning device shall be installed pursuant to the standards and specifications defined by the manufacturer of that device, or shall meet the clearances specified in the *2003 International Mechanical Code*. The installation of any solid-fuel burning device shall be subject to inspection and approval by the Gunnison County Building Inspector and by the applicable Fire Protection District in which the device is located.

I have read the above requirements for Installation of Solid Fuel-Burning Devices, Section 13-107 in the Gunnison County Land Use Resolution, and agree to comply with the installation of an approved solid fuel-burning device as certified by the U.S. Environmental Protection Agency, or is certified to meet those standards by a testing laboratory accredited by the E.P.A. and acknowledge that the installation of a solid fuel-burning device is subject to inspection by the County.

Signature of Owner(s) _____

CHAPTER 9

SPECIFIC APPLIANCES, FIREPLACES AND SOLID FUEL-BURNING EQUIPMENT

SECTION 901 GENERAL

901.1 Scope. This chapter shall govern the approval, design, installation, construction, maintenance, alteration and repair of the appliances and equipment specifically identified herein and factory-built fireplaces. The approval, design, installation, construction, maintenance, alteration and repair of gas-fired appliances shall be regulated by the *International Fuel Gas Code*.

901.2 General. The requirements of this chapter shall apply to the mechanical equipment and appliances regulated by this chapter, in addition to the other requirements of this code.

901.3 Hazardous locations. Fireplaces and solid fuel-burning appliances shall not be installed in hazardous locations.

901.4 Fireplace accessories. Listed fireplace accessories shall be installed in accordance with the conditions of the listing and the manufacturer's installation instructions.

SECTION 902 MASONRY FIREPLACES

902.1 General. Masonry fireplaces shall be constructed in accordance with the *International Building Code*.

SECTION 903 FACTORY-BUILT FIREPLACES

903.1 General. Factory-built fireplaces shall be listed and labeled and shall be installed in accordance with the conditions of the listing. Factory-built fireplaces shall be tested in accordance with UL 127.

903.2 Hearth extensions. Hearth extensions of approved factory-built fireplaces and fireplace stoves shall be installed in accordance with the listing of the fireplace. The hearth extension shall be readily distinguishable from the surrounding floor area.

903.3 Unvented gas log heaters. An unvented gas log heater shall not be installed in a factory-built fireplace unless the fireplace system has been specifically tested, listed and labeled for such use in accordance with UL 127.

SECTION 904 PELLET FUEL-BURNING APPLIANCES

904.1 General. Pellet fuel-burning appliances shall be listed and labeled and shall be installed in accordance with the terms of the listing.

SECTION 905 FIREPLACE STOVES AND ROOM HEATERS

905.1 General. Fireplace stoves and solid-fuel-type room heaters shall be listed and labeled and shall be installed in accordance with the conditions of the listing. Fireplace stoves shall be tested in accordance with UL 737. Solid-fuel-type room heaters shall be tested in accordance with UL 1482. Fireplace inserts intended for installation in fireplaces shall be listed and labeled in accordance with the requirements of UL 1482 and shall be installed in accordance with the manufacturer's installation instructions.

905.2 Connection to fireplace. The connection of solid fuel appliances to chimney flues serving fireplaces shall comply with Sections 801.7 and 801.10.

SECTION 906 FACTORY-BUILT BARBECUE APPLIANCES

906.1 General. Factory-built barbecue appliances shall be of an approved type and shall be installed in accordance with the manufacturer's installation instructions, this chapter and Chapters 3, 5, 7, 8 and the *International Fuel Gas Code*.

SECTION 907 INCINERATORS AND CREMATORIES

907.1 General. Incinerators and crematories shall be listed and labeled in accordance with UL 791 and shall be installed in accordance with the manufacturer's installation instructions.

SECTION 908 COOLING TOWERS, EVAPORATIVE CONDENSERS AND FLUID COOLERS

908.1 General. A cooling tower used in conjunction with an air-conditioning appliance shall be installed in accordance with the manufacturer's installation instructions.

908.2 Access. Cooling towers, evaporative condensers and fluid coolers shall be provided with ready access.

908.3 Location. Cooling towers, evaporative condensers and fluid coolers shall be located to prevent the discharge vapor plumes from entering occupied spaces. Plume discharges shall be not less than 5 feet (1524 mm) above or 20 feet (6096 mm) away from any ventilation inlet to a building. Location on the property shall be as required for buildings in accordance with the *International Building Code*.

908.4 Support and anchorage. Supports for cooling towers, evaporative condensers and fluid coolers shall be designed in accordance with the *International Building Code*. Seismic restraints shall be as required by the *International Building Code*.